

# Manual

## Conveyor Toaster

Model:

**CT280/400 ADV**

**CT280/400 MAN/STEEL**

**CT280/400 STD/STEEL**

**CT400 STD P, CT400 ADV P**

**CT550 STD P, CT550 ADV P**

**Type code: ACT-23; SCT-23; MCT-23**

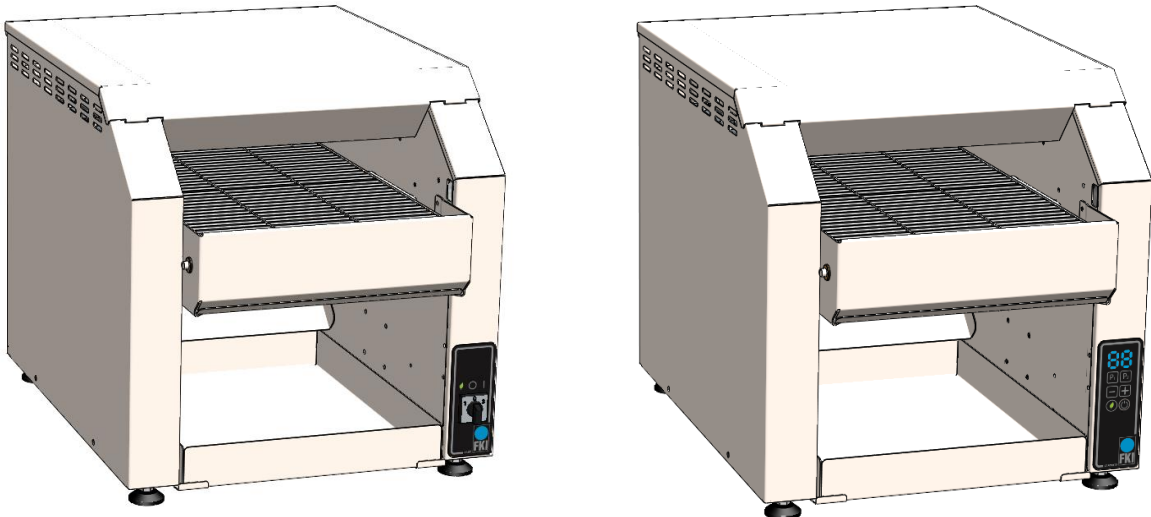

**FKI Fast Food Teknik a/s**

Version 12.0

## Content

1.1	General .....	4
1.1.1	Appliance description .....	4
1.1.2	Manufacturer.....	4
1.1.3	Appliance label.....	5
1.1.4	Technical specifications and power consumption.....	5
1.1.5	Modification.....	6
2	Safety.....	6
2.1	Personal safety equipment.....	7
2.2	Potential hazards .....	7
2.3	Who may use the appliance .....	7
2.4	Transport/installation/fastening .....	8
2.4.1	Transport .....	8
2.4.2	Installation .....	8
2.4.3	Fixation .....	9
2.5	Operation.....	9
2.6	Cleaning/maintenance .....	9
2.7	Servicing.....	9
3	Operation.....	10
3.1	Before first use .....	10
3.1.1	CT280/CT400 ADV.....	10
3.1.2	CT280/CT400 STD .....	11
3.1.3	Repairs and spare parts .....	12
3.2	Specifications for spare parts .....	12
3.2.1	Spare parts CT280 ADV.....	13
3.2.2	Spare parts CT280 MAN.....	14
3.2.3	Spare parts CT280 STD STEEL .....	15
3.2.4	Spare parts CT280 MAN STEEL .....	16
3.2.5	Spare parts CT400 ADV.....	17
3.2.6	Spare parts CT400 MAN.....	18
3.2.7	Spare parts CT400 STD STEEL .....	19
3.2.8	Spare parts CT400 MAN STEEL .....	20
3.2.9	Spare parts CT550 STD P.....	21

3.2.10	Spare parts CT550 ADV P.....	22
3.2.11	Electrical diagrams .....	23
4	Cleaning.....	33
4.1	General .....	33
4.2	Daily cleaning.....	33
5	Disposal.....	33
5.1	Packaging.....	33
5.2	When the Appliance is no longer required.....	33
6	EU DECLARATION OF CONFORMITY .....	34

Introduction

### **Original user instructions**

These instructions are FKI Fast Food Teknik's original instructions for the appliance.

### **The purpose of these instructions**

These instructions are intended to ensure the correct installation, use, handling, and maintenance of the Combi Toaster. **Hereinafter referred to as "the appliance"**.



**Important! Read these instructions carefully before use and keep them safe for later use.**

### **Storage of these instructions**

You must retain these instructions and make sure that they are easily accessible to users and service technicians.

### **Understanding these instructions**

It is the responsibility of the appliance's owner to ensure that anyone who will be operating, servicing, maintaining, or repairing the appliance has read these instructions and, by way of minimum, the sections that are of relevance to the work they will perform.

Anyone who will be operating, servicing, maintaining, or repairing the appliance, is required to look up any relevant information in these instructions.

## 1.1 General

### 1.1.1 Appliance description

The appliance is intended for placement on a table at a suitable working height and is operated from the front.

### 1.1.2 Manufacturer

FKI Fast Food Teknik a/s  
Byghøjvej 5, Verringe  
DK-5690 Tommerup  
[www.fki.dk](http://www.fki.dk)

### 1.1.3 Appliance label

1.1.3.1 Type code CT280/CT400 ADV: ACT-23

Type code CT280/CT400 STD: STD-23



### 1.1.4 Technical specifications and power consumption

#### 1.1.4.1 Dimensions and weight

Modelbetegnelse	Bredde x dybde x højde	Vægt i kg
CT280 ADV	412 x 545 x 430 mm	21,5
CT280 STD	412 x 545 x 430 mm	21
CT280 MAN	412 x 545 x 430 mm	21
CT280 STD STEEL (R)	412 x 545 x 430 mm	22,5
CT280 MAN STEEL (R)	412 x 545 x 430 mm	21
CT400 ADV	532 x 545x 430 mm	24,5
CT400 STD	532 x 545 x 430 mm	23
CT400 MAN	532 x 545 x 430 mm	23
CT400 STD STEEL (R)	532 x 545 x 430 mm	25,5
CT400 MAN STEEL (R)	532 x 545 x 430 mm	23

#### 1.1.4.2 Power

Connection voltage: 230 V AC

Connection frequency: 50/60 Hz

Model	Voltage/Power	Power consumption [Amp.]
CT280 ADV	230V/2,2 kW	9,5 A
CT280 STD	230V/2,2 kW	9,5 A
CT280 MAN	230V/2,2 kW	9,5 A
CT400 ADV	230V/2,2 kW	9,5 A
CT400 STD	230V/2,2 kW	9,5 A
CT400 MAN	230V/2,2 kW	9,5 A
CT400 STD P	230V/3,2 kW	16 A
CT400 ADV P	400V/3,2 kW	8 A
CT550 STD P	400V/5,2 kW	13 A
CT550 ADV P	400V/5,2 kW	13 A

#### Noise

Airborne noise emitted by the Device:

Measured sound level: < 65 dB(A)

#### 1.1.4.3 Intended use

The appliance is only to be used for food preparation.

#### 1.1.5 Modification

The appliance must never be modified or serviced by unauthorised personnel. In the event of non-compliance, FKI Fast Food Teknik A/S disclaims any and all liability.

## 2 Safety

### General

Read these safety instructions before using the appliance. Keep them near to the appliance for later reference. These instructions and the appliance itself are provided with important safety information that must always be read and always observed. FKI Fast Food Teknik A/S denies any and all liability for non-compliance with these safety instructions, for inappropriate use of the appliance or the use of incorrect settings.

## 2.1 Personal safety equipment



is recommended that gloves and goggles are worn when working with the appliance, as the surfaces of the Combi Toaster are hot and there may be a risk of hot grease.

## 2.2 Potential hazards



When the appliance is in use, the user should be aware that the appliance is hot. Do not touch the warm surfaces or the conveyor band transporting the bread through the appliance without wearing protective gloves. Therefore, be careful not to touch these surfaces during operation.



During operation, only the buttons on the front may be touched. The food that is toasted in the toaster must be inserted and removed using a specially designed tool to avoid contact with the hot surfaces of the appliance.

## 2.3 Who may use the appliance



This appliance is not intended for use by children! Neither should it be used by persons with reduced physical or mental capacity, or who lack appropriate experience and knowledge unless they have been trained or instructed in the use by someone responsible for their safety.

## 2.4 Transport/installation/fastening

### 2.4.1 Transport

The appliance is supplied in transport packaging and should only be transported in the same way if it is moved.

**WARNING: The machine must not be moved during operation.**



Moving and setting up the appliance must be performed by two or more people!

**RISK of injury!**

Wear protective gloves and safety footwear during unpacking and installation  
- cut hazard.

### 2.4.2 Installation

The appliance shall be placed on a suitable worktop or similar at a suitable working height. The appliance is operated from the front. The device is intended for placement on a table or counter and is equipped with adjustable legs.



Connection of the appliance should be carried out by an authorized electrician. The Combi Toaster is equipped with a grounded 1-pole plug (F+N+J). Be aware that the installation has been carried out correctly with sufficient fuse size, protection against fault current and grounding.



**WARNING: This appliance must be properly grounded. Failure to do so may cause electric shock and serious injury.**



The appliance must be acclimatized before use. It should therefore not be started up until eight hours have elapsed.



The power supply must be able to be disconnected, either by unplugging or by means of a freely accessible multi-pole switch located before the power outlet in accordance with applicable electricity regulations. The appliance must be grounded in accordance with national safety standards for electrical appliances.



Do not use extension cords or multi-socket outlets. After installation is completed there must be no direct access to the electrical components. Never touch the appliance if you are wet or have bare feet. Do not use this appliance if the power cord or plug is damaged, if the appliance is not working properly, if it is damaged or if it has been dropped on the floor.





Any replacement of the power cord must be performed by an authorised technician to avoid the risk of personal injury - RISK of electric shock. Only use oil-resistant cables!

### 2.4.3 Fixation



The appliance does not need to be secured. It is equipped with adjustable legs to ensure stable and easy installation.

## 2.5 Operation



The appliance must be supervised during use and must be switched off at its main switch if left.



The appliance is intended for food preparation only. Do not apply liquids or other substances that have an ignition point below 300° C.

## 2.6 Cleaning/maintenance



**CLEANING AND MAINTENANCE WARNING:** Do not use products that contain acid, as they may damage the surface of the appliance.

It is important that the Conveyor Toaster's waste tray/reflector plate is emptied regularly of breadcrumbs, otherwise these will burn onto the surface.

Daily cleaning is done when the Conveyor Toaster has cooled down. The waste tray is emptied of breadcrumbs and washed with a damp cloth. The conveyor toaster is cleaned by wiping with damp cloth on the outside.

Once a day, clean the appliance thoroughly and wipe all external surfaces with a damp cloth.

Cleaning should not be carried out when the Appliance is more than 50°C hot.



Never use steam/foam cleaners due to RISK of electric shock.

## 2.7 Servicing



The appliance must always be switched off and disconnected from the power source before commencing repairs. Repair of the Appliance should only be carried out by authorized personnel.

## 3 Operation

### 3.1 Before first use



Before start-up, remove all packaging and protective plastic from the appliance and dispose of it in accordance with currently applicable regulations (see section 5.1). Carefully read section 2 about safety before connecting the appliance.



Before start-up, clean the appliance as shown in [section 4](#).

#### 3.1.1 CT280/CT400 ADV

As a starting point the Conveyor Toaster is delivered in sensor mode with two heating elements turned on, set to the lowest speed and with the ECO button turned off. The sensor lights up (in red) the black plate on the left side of the toaster. When a loaf of bread is inserted and the red light is broken, even briefly, the other two heating elements are switched on and the belt starts running until the belt has run one lap, however, the belt's counter is reset if the red light is broken again.

##### ECO Function with sensor

If you wish all heating elements to be switched off when there are no products in the Conveyor Toaster, press the ECO button, which will then be illuminated. Now all heating elements turn off after toasting is finished and there are no products in the Conveyor Toaster. When the red light is broken again, all four heating elements will be turned on while 10 seconds pass before the belt starts running.

##### Program keys P1 and P2

P1 and P2 can be programmed, as a shortcut to frequently used speeds. Set the speed using +/- Then hold down either P1 or P2 for three seconds to save the setting. When P1 or P2 is pressed, the speed will change to the stored speed and selected program button will light up. If the speed changed (+/- button) in program mode, the selected program will be switched off.

The speed can be adjusted on +/- in increments of one step. If either minus or plus is held down, the Conveyor Toaster will adjust several steps quickly, while a single press only changes the speed of individual steps.

The Conveyor Toaster is switched off on the standby symbol, and is also switched on using this button.



### ECO Function without sensor

If you wish the sensor deactivated, this can be done by having the Conveyor Toaster turned on and holding down the ECO button for three seconds. The conveyor toaster turns off. The next time the Conveyor Toaster is turned on, the sensor will be inactive, this can be noticed by the fact that there is no longer a red light on the black plate to the left of the band. The same procedure is repeated if the sensor is to be activated again.

When the sensor is deactivated, the Conveyor Toaster will have all four heating elements turned on and the belt will be running all the time. If the ECO button is pressed and lights up, the two middle heating elements will remain turned on and the belt will stop until the ECO button is pressed and the light turned off again.

All settings will be saved. That is, the Conveyor Toaster can be moved to another location without losing the settings.

### Normal Mode or Burger Bun Mode:

At the rear of the Conveyor Toaster there is a switch with three positions.

- “I”, Normal mode where the four rear heating elements are used.
- Center position is a setting where only the two middle heating elements are active.
- ”II”, Burger bun mode where the top three and the bottom middle heating element is in use.

### 3.1.2 CT280/CT400 STD

The conveyor Toaster comes with four heating elements turned on and with fixed speed on the belt.

- If the switch is set to position 1 (ECO), the Conveyor Toaster will turn off two heating elements and stop the belt.
- If the switch is set to position 0 (OFF), everything will be off.
- If the switch is set to position 2 (ON), all four heating elements will be turned on and the belt will run.

### Normal Mode or Burger Bun Mode:

At the rear of the Conveyor Toaster there is a switch with three positions.

- “I”, Normal mode where the four rear heating elements are used.
- Center position is a setting where only the two middle heating elements are active.
- ”II”, Burger bun mode where the top three and the bottom middle heating element is in use

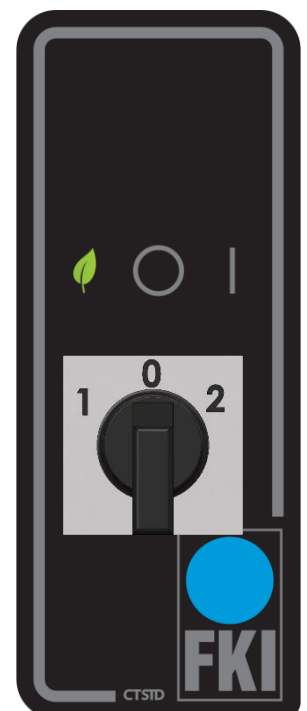

### 3.1.3 Repairs and spare parts

Repairs should only be carried out by authorized service personnel with knowledge of electrical equipment.

## 3.2 Specifications for spare parts

### 3.2.1 Spare parts CT280 ADV

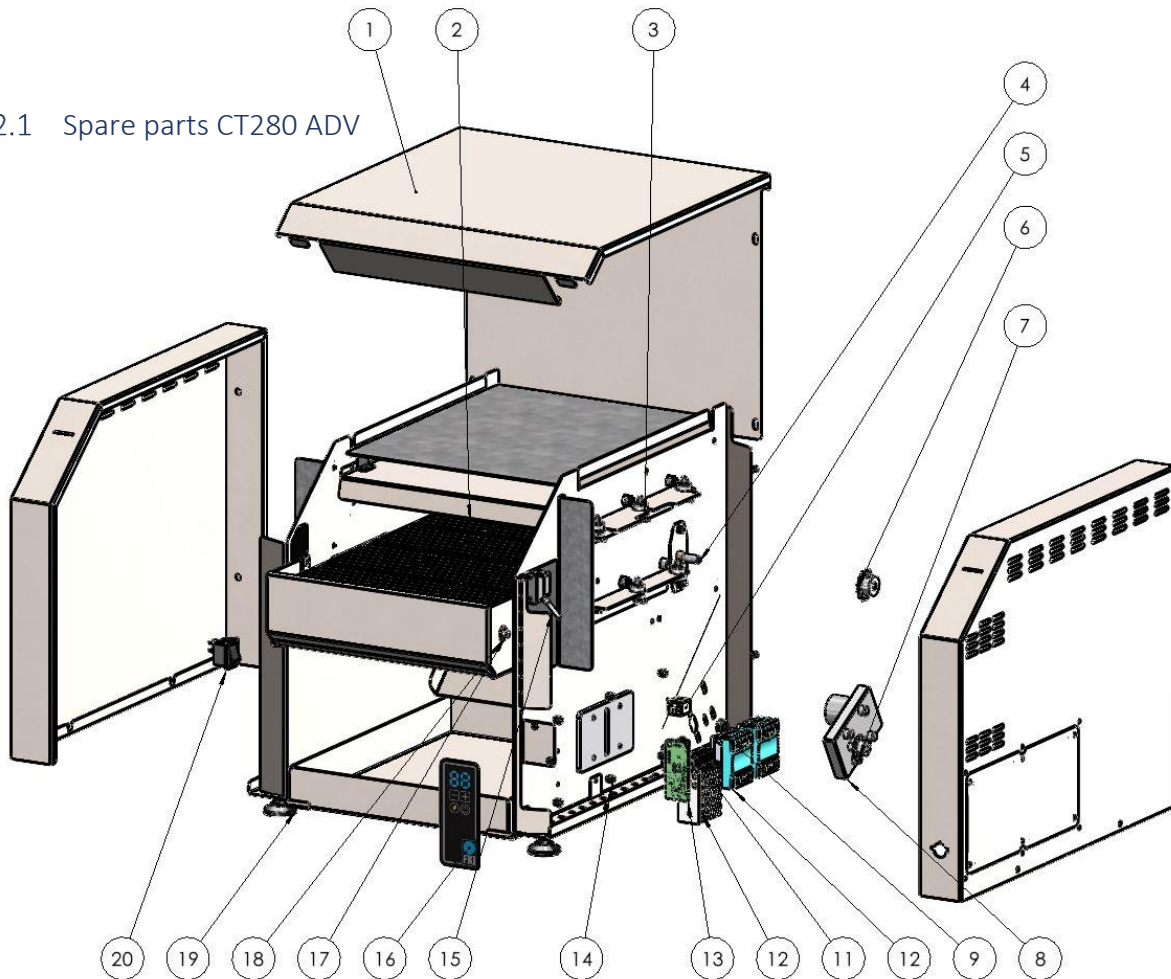

POS	Part No.	Pcs.	Description
1	13-80285	1	Cabinet parts CT280 ADV
2	83-08458	1	Conveyor belt
3	83-08596	10	Insulator set for Quartz tube
3	83-08595	5	Quartz tube
3	83-08654	5	Heating element (Spiral)
4	83-09531	1	Drive Shaft UT280
5	72-03508	1	Terminal Block 2-POL Porcelain
6	83-08616	1	Chainwheel Cog NAV 05B1 Z13 Ø8 M5
7	83-08584	1	Chainwheel Cog M8X3 Z10 Ø8 M4
8	83-10027	1	Gearmotor UT-V, DME34B5500B 24Vdc
9	72-03570	1	Cable support Black plastic
12	88-00231	2	Solid state relay 4-32VDC 48-660VAC 60A
11	83-07523	1	Cable router Ø10
12	83-10028	1	Power supply 100-240V/0,35A - 12V/1,3A
13	72-01326	1	Print Conveyor Toaster
14	78-03105	16	NITTE MØTRIK, M4 UH, 6KT. open FZB (BN7773)
15	72-07033	1	Sensor Diffuse reflector O6T304
16	72-05524	1	Foil for CT ADV
17	83-08471	1	Axel complete
18	83-08688	2	Bronze bearing Ø8/12X12 w. collar TYPE B
19	82-06510	4	Leg M8 Adjustable
20	83-07908	1	Switch 2-POLE

### 3.2.2 Spare parts CT280 MAN

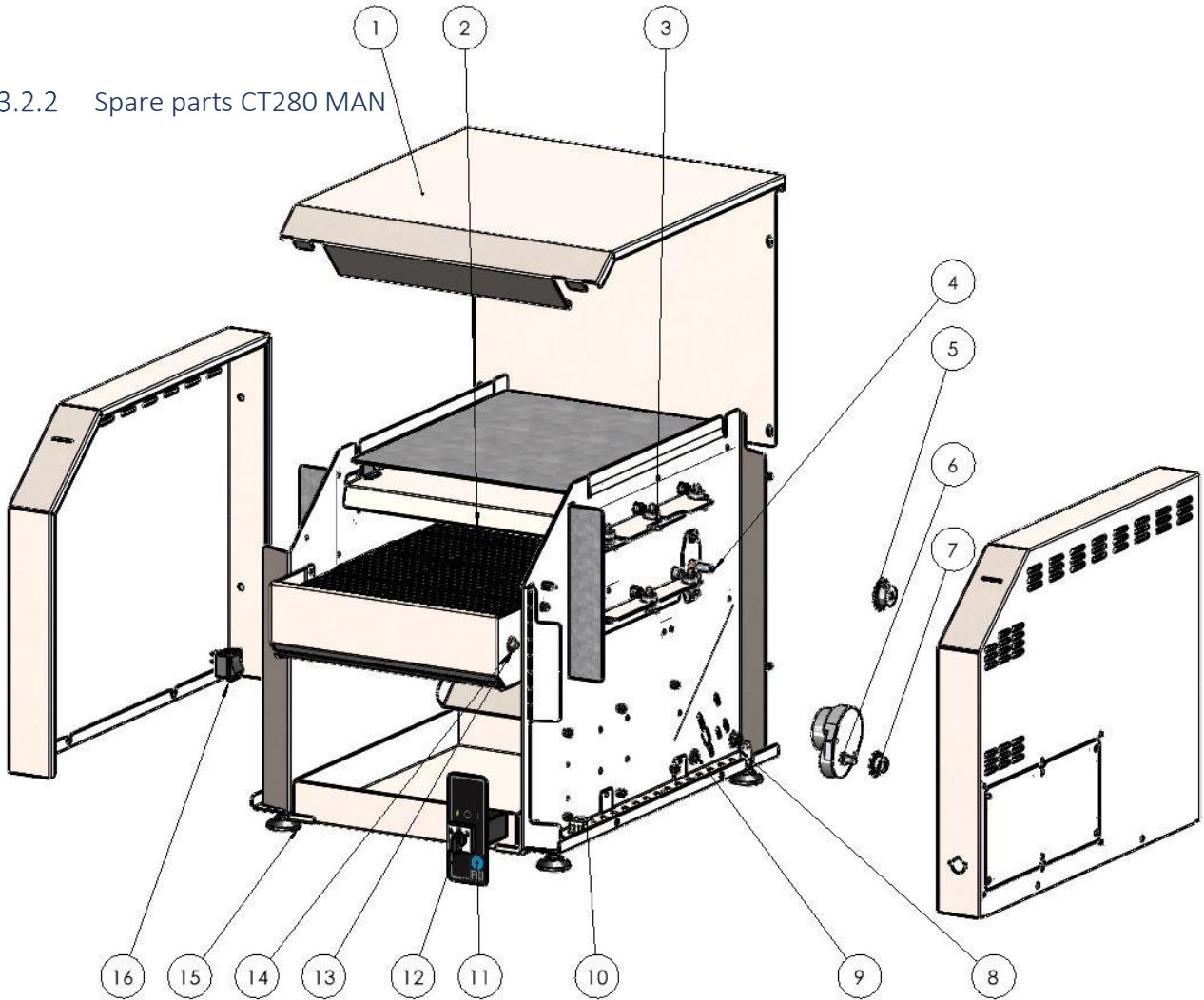

POS	Part No.	Pcs.	Description
1	13-80280	1	Cabinet parts CT280 STD
2	83-08458	1	Conveyor belt
3	83-08596	10	Insulator set for Quartz tube
3	83-08595	5	Quartz tube
3	83-08654	5	Heating element (Spiral)
4	83-09531	1	Drive Shaft UT280
5	83-08616	1	Chainwheel Cog 05B1 Z13 Ø8 M5 Pinol
6	83-06595	1	Gearmotor SAIA UT 280/400
7	83-08584	1	Chainwheel Cog M8X3 Z10 Ø8 PINOL M4
8	72-03570	1	Cable support Black plastic
9	83-07523	1	Cable router Ø10
10	72-03508	1	Terminal Block 2-POL PORCELÆN
11	72-05525	1	Foil for CT STD
12	83-41018	1	Switch 3-POL TELUX 10A
13	83-08471	1	Axel complete
14	83-08688	2	Bronze bearing Ø8/12X12 M KRAVE TYPE B
15	82-06510	4	Leg M8
16	83-07908	1	Switch 2-POL

### 3.2.3 Spare parts CT280 STD STEEL

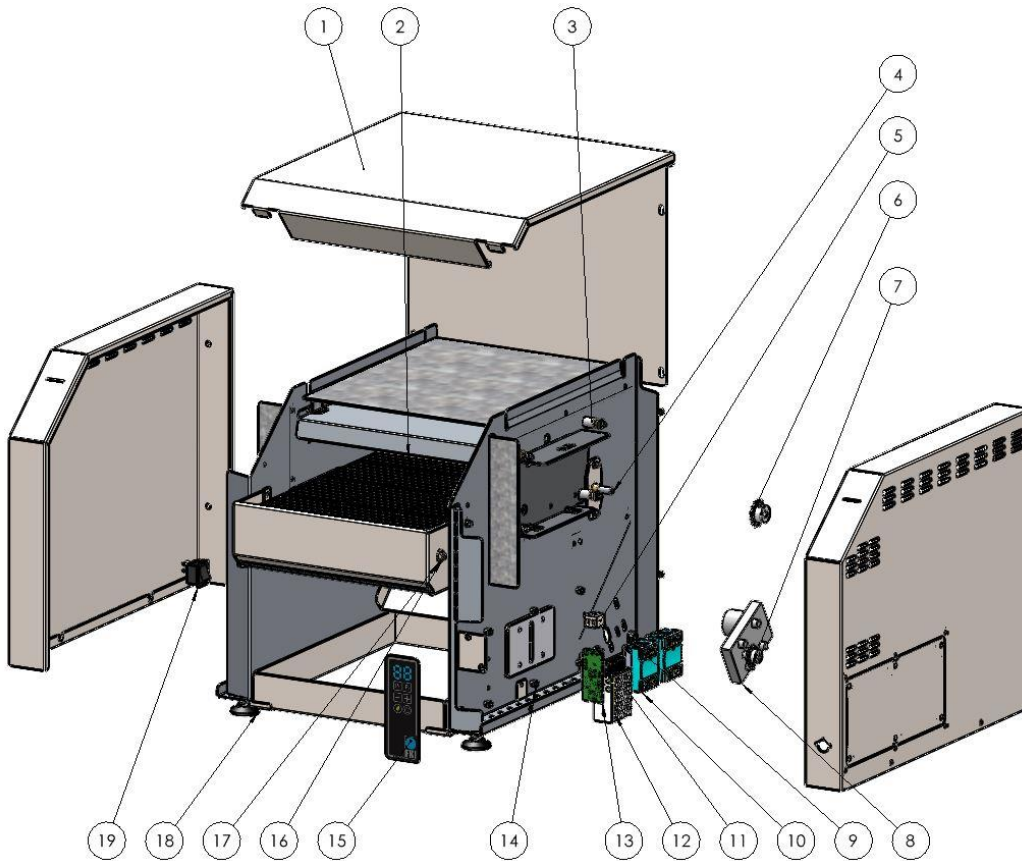

POS	VARE NUMMER	STK	BENÆVNELSE
1	13-80291		Cabinet parts CT280 STD STEEL
2	83-08458_920mm	1	Conveyor belt
3	83-08530	2	Heat element UT280 1kW/230V
4	83-09531	1	Drive shaft UT280
5	72-03508	1	Terminal block 2-POL
6	83-08616	1	Chainwheel NAV 05B1 Z13 Ø8 M5
7	83-08584	1	Chainwheel NAV M8X3 Z10 Ø8 M4
8	83-10027	1	GEARMOTOR UT-V, DME34B5500B 24Vdc
9	72-03570	1	Cable support
10	88-00231	2	SOLIDSTATE SSR 4-32VDC 48-660VAC 60A
11	83-07523	1	Cable router Ø10
12	83-10028	1	Power supply 100-240V/0,35A - 12V/1,3A
13	72-01326	1	PRINT CONVEYOR TOASTER
14	78-03105	16	NUT
15	72-05524	1	FOLIE FOR CT ADV
16	83-08471	1	Axel complete
17	83-08688	2	bearing Ø8/12X12
18	82-06510	4	BlegM8
19	83-07908	1	switch 2-POL

### 3.2.4 Spare parts CT280 MAN STEEL

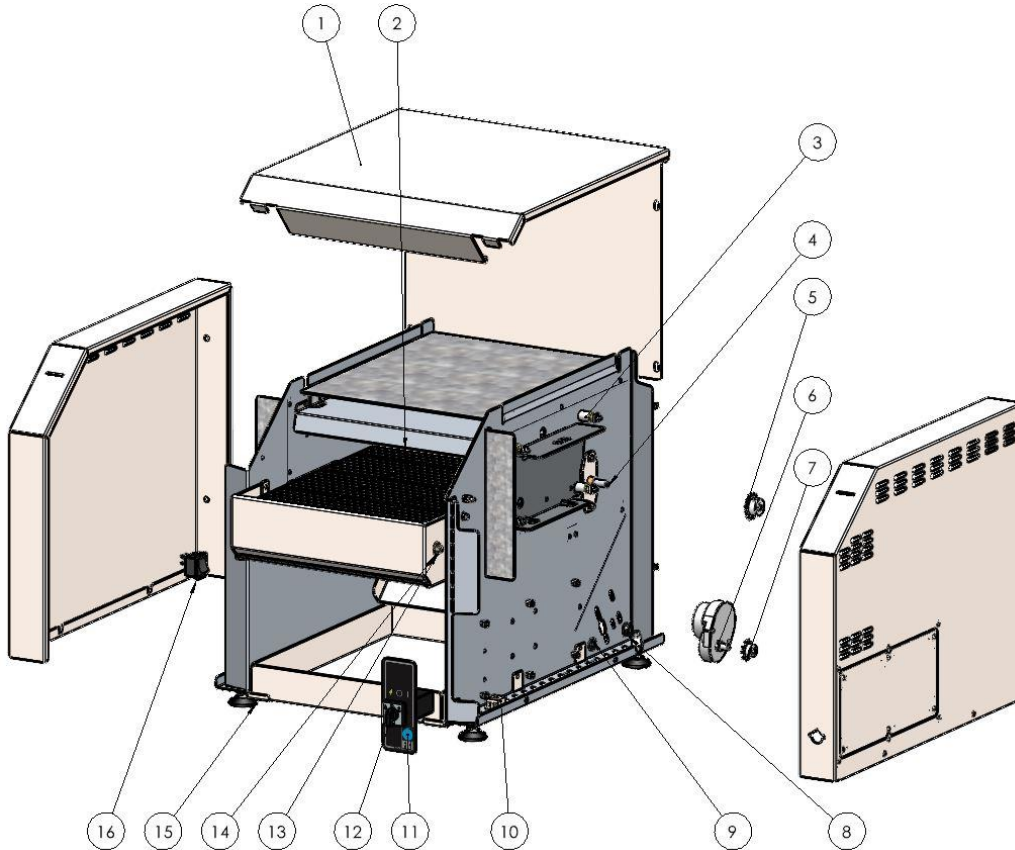

POS	VARE NUMMER	STK	BENÆVNELSE
1	13-80290	1	Cabinet parts CT280 MAN STEEL
2	83-08458_920mm	1	Conveyor belt
3	83-08530	2	Heat element UT280 1kW/230V
4	83-09531	1	Drive shaft UT280
5	83-08616	1	Chainwheel NAV 05B1 Z13 Ø8 M5
6	83-06595	1	GEARMOTOR SAIA UT 280/400
7	83-08584	1	chainwheel NAV M8X3 Z10 Ø8 M4
8	72-03570	1	Cable support
9	83-07523	1	Cable router Ø10
10	72-03508	1	Terminal block 2-POL
11	72-05525	1	FOLIE FOR CT STD
12	83-41018	1	Switch 3-POL TELUX 10A
13	83-08471	1	Axel complete
14	83-08688	2	bearing Ø8/12X12
15	82-06510	4	leg M8
16	83-07908	1	switch 2-POL



### 3.2.5 Spare parts CT400 ADV

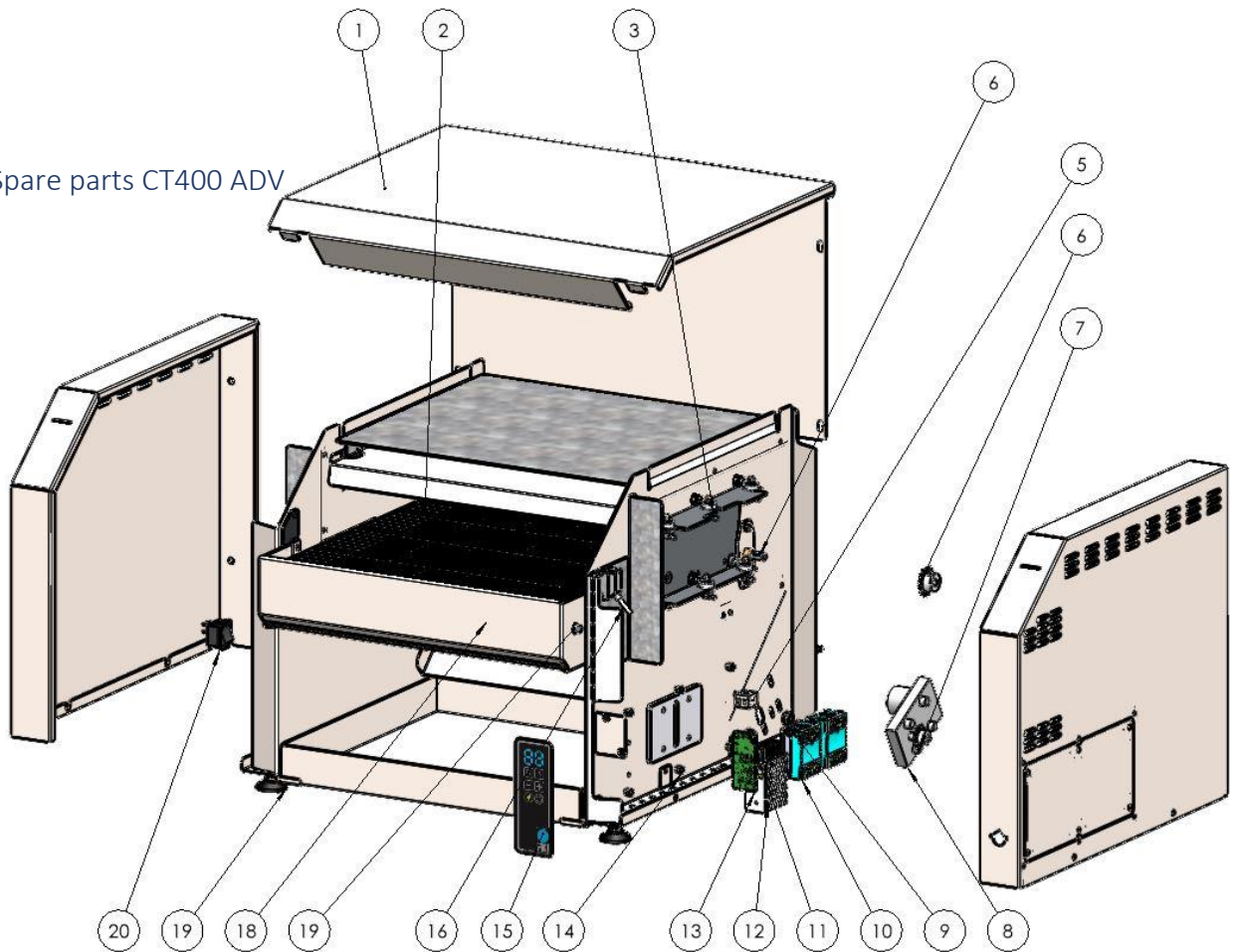

POS	VARE NUMMER	STK	BENÆVNELSE
1	13-80405	1	Cabinet Parts CT400 ADV
2	83-08879	1	Conveyor belt
3*	83-08596	10	Insulator set for Quartz tube
3*	83-08883	5	Quartz tube
3*	83-08654	5	Heating element (Spiral)
6	83-09533	1	Drive Shaft UT400
5	72-03508	1	Terminal 2-POL
6	83-08616	1	Chainwheel 05B1 Z13 Ø8 M5
7	83-08584	1	chainwheel M8X3 Z10 Ø8 M4
8	83-10027	1	GEARMOTOR UT-V, DME34B5500B 24Vdc
9	72-03570	1	Cable support Black plastic
12	88-00231	2	SOLIDSTATE 4-32VDC 48-660VAC 60A
11	83-07523	1	Cable router Ø10
12	83-10028	1	PSU 100-240V/0,35A - 12V/1,3A
13	72-01326	1	PRINT CONVEYOR TOASTER
14	78-03105	16	NUT
15	72-05524	1	Foil for CT ADV
16	72-07033	1	SENSOR DIFFUS REFLEKTOR O6T304
19	83-08480	1	shaft UT400/UT400V
18	83-08688	2	bearing Ø8/12X12
19	82-06510	4	leg M8
20	83-07908	1	switch 2-POL
*Pos.3 - 12 insulator set and 6 stk. heatelements at Performance models (P)			

### 3.2.6 Spare parts CT400 MAN

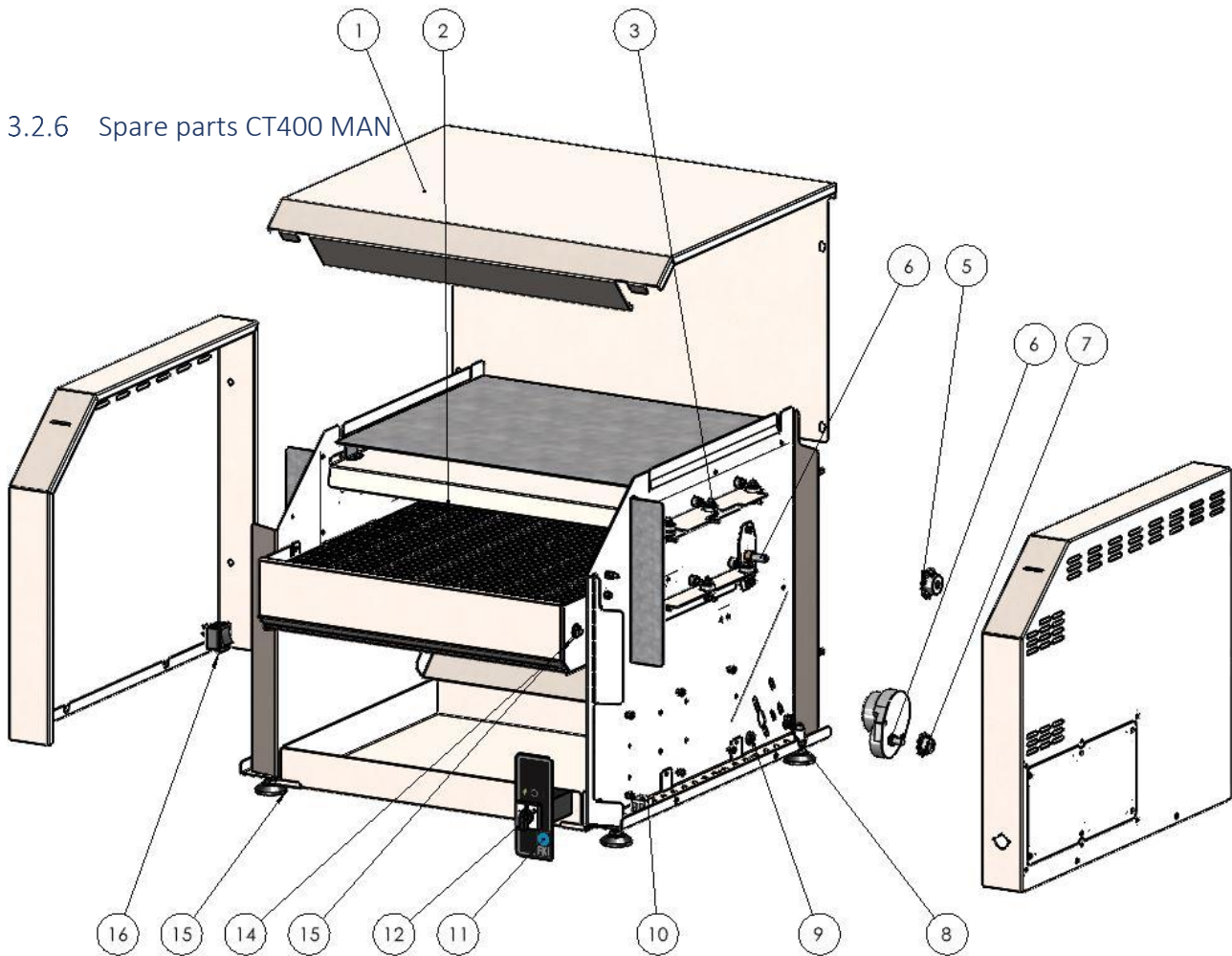

POS	VARE NUMMER	STK	BENÆVNELSE
1	13-80400	1	Cabinet Parts CT400 STD
2	83-08879	1	Conveyor belt
3*	83-08596	10	Insulator set for Quartz tube
3*	83-08883	5	Quartz tube
3*	83-08654	5	Heating element (Spiral)
6	83-09533	1	Drive Shaft UT400
5	83-08616	1	Chainwheel 05B1 Z13 Ø8 M5
6	83-06595	1	GEARMOTOR SAIA UT 280/400
7	83-08584	1	chainwheel M8X3 Z10 Ø8 M4
8	72-03570	1	Cable support Black plastic
9	83-07523	1	Cable router Ø10
10	72-03508	1	terminal 2-POL
11	72-05525	1	Foil FOR CT STD
12	83-41018	1	switch 3-POL TELUX 10A
15	83-08480	1	shaft UT400/UT400V
14	83-08688	2	bearing Ø8/12X12
15	82-06510	4	Leg M8
16	83-07908	1	switch 2-POLET

\*Pos.3 - 12 insulator set and 6 stk. heatelements at Performance models (P)

### 3.2.7 Spare parts CT400 STD STEEL

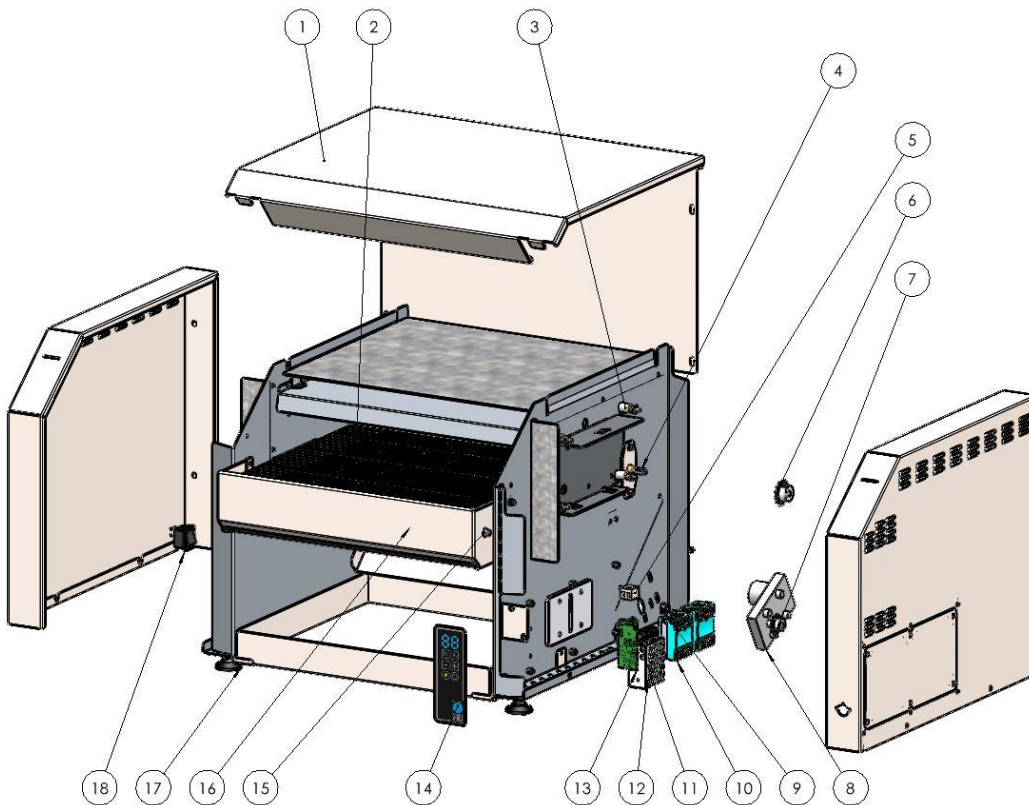

POS	VARE NUMMER	STK	BENÆVNELSE
1	13-80421	1	Cabinet parts CT400 STD STEEL
2	83-08879_920mm	1	Conveyor belt
3	83-08531	2	Heat element UT400 1kW/230V
4	83-09533	1	driveshaft UT400
5	72-03508	1	Terminal block 2-POL PORCELÆN
6	83-08616	1	chainwheel NAV 05B1 Z13 Ø8 M5
7	83-08584	1	chainwheel NAV M8X3 Z10 Ø8 M4
8	83-10027	1	GEARMOTOR UT-V, DME34B5500B 24Vdc
9	72-03570	1	Cable support
10	88-00231	2	SOLIDSTATE SSR 4-32VDC 48-660VAC 60A
11	83-07523	1	Cable router
12	83-10028	1	Power supply 100-240V/0,35A - 12V/1,3A
13	72-01326	1	PRINT CONVEYOR TOASTER
14	72-05524	1	FOLIE FOR CT ADV
15	83-08480	1	Axel UT400/UT400V
16	83-08688	2	bearing Ø8/12X12
17	82-06510	4	leg M8
18	83-07908	1	switch 2-POL

### 3.2.8 Spare parts CT400 MAN STEEL

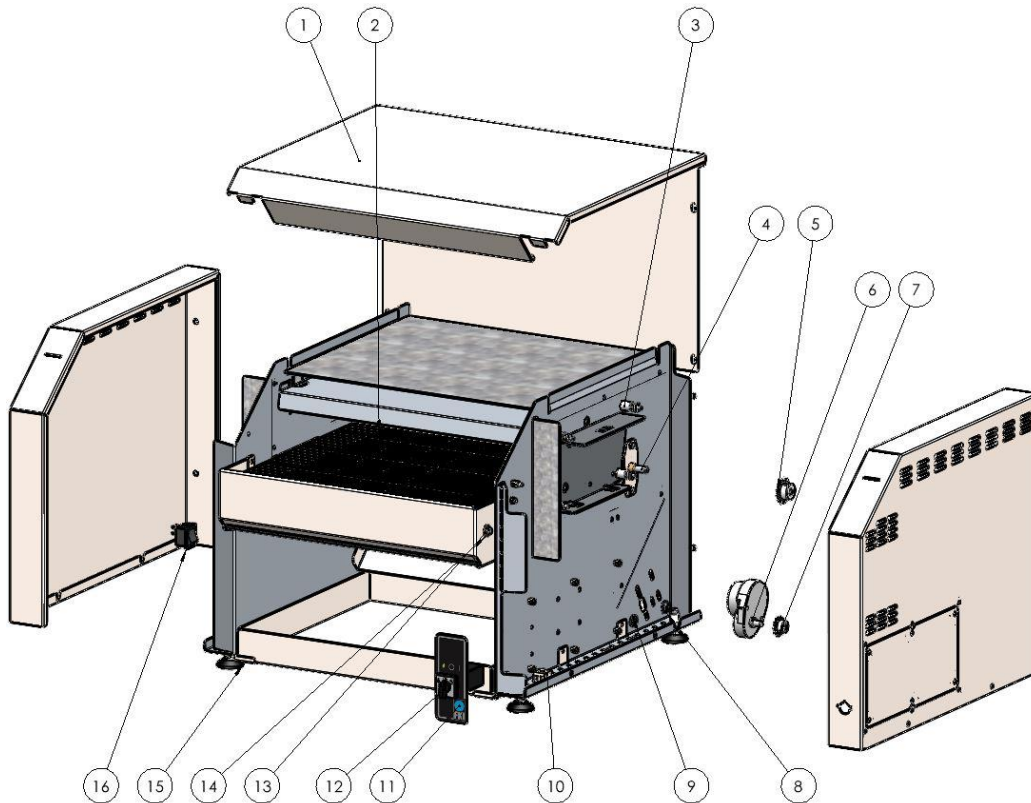

POS	VARE NUMMER	STK	BENÆVNELSE
1	13-80420	1	Cabinet parts CT400 MAN STEEL
2	83-08879_920mm	1	Conveyor belt
3	83-08531	2	Heat element UT400 1kW/230V
4	83-09533	1	Drive shaft UT400
5	83-08616	1	chainwheel NAV 05B1 Z13 Ø8 M5
6	83-06595	1	GEARMOTOR SAIA UT 280/400
7	83-08584	1	Chainwheel NAV M8X3 Z10 Ø8 M4
8	72-03570	1	Cable support
9	83-07523	1	Cable router
10	72-03508	1	Terminal block 2-POL
11	72-05525	1	FOLIE FOR CT STD
12	83-41018	1	switch 3-POL TELUX 10A
13	83-08480	1	axel UT400/UT400V
14	83-08688	2	bearing Ø8/12X12
15	82-06510	4	Leg M8
16	83-07908	1	switch 2-POL

### 3.2.9 Spare parts CT550 STD P

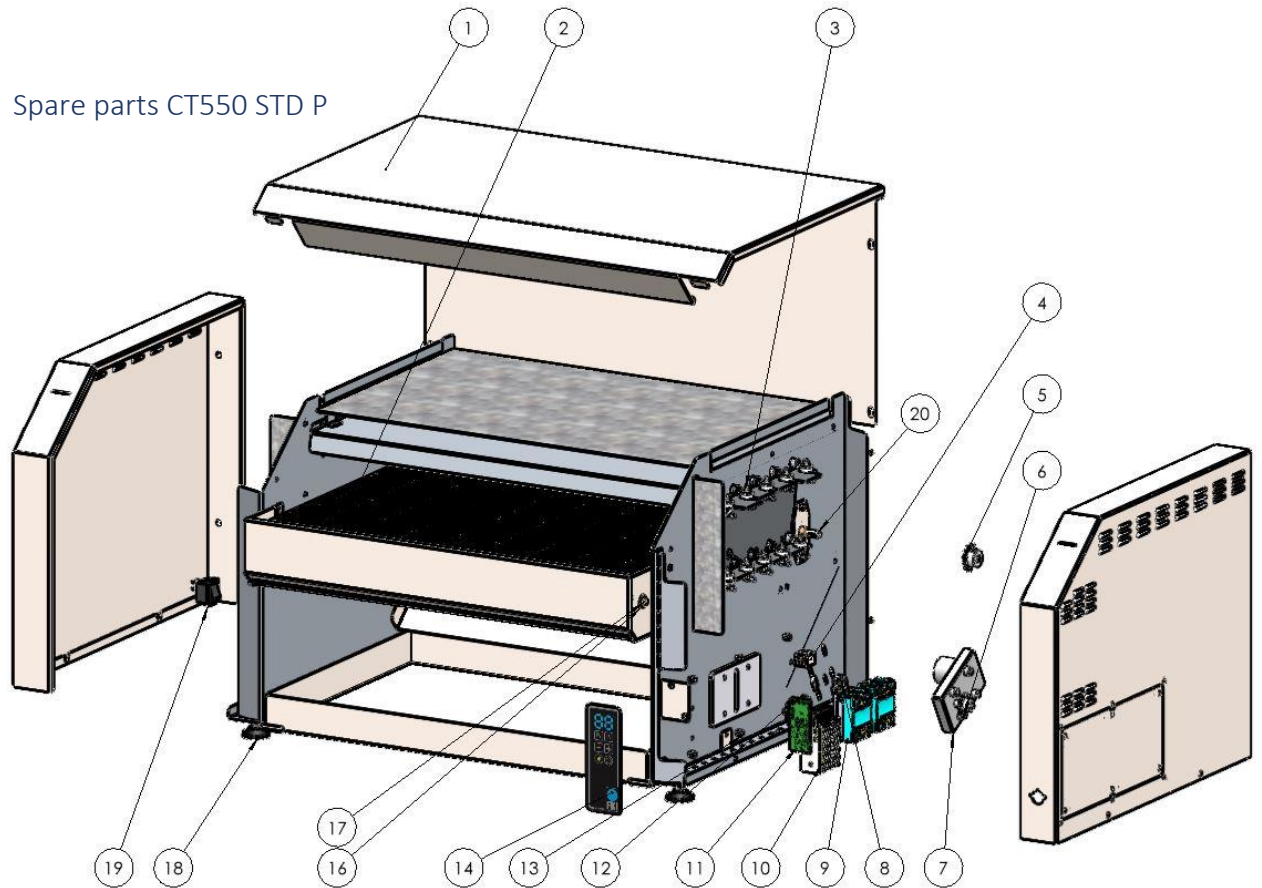

POS	VARE NUM-MER	STK	BENÆVNELSE
1	13-80550	1	Cabinet parts CT550 STD
2	83-10343	1	Conveyor belt 559x1,83x12,7MM (920mm)
3	83-08596	20	insulator FOR QUARTTUBE
3	83-08595	10	QUARTSTUBE
3	83-08654	10	Heatelement
4	72-03508	1	Terminal 2-POL
5	83-08616	1	chainwheel 05B1 Z13 Ø8 M5 pinol
6	83-08584	1	chainwheel M8X3 Z10 Ø8 PINOL M4
7	83-10027	1	GEARMOTOR UT-V, DME34B5500B 24Vdc
8	72-07021	1	Cable connector M20 Ø3,5-8
9	88-00231	2	SOLIDSTATE 4-32VDC 48-660VAC 60A
10	83-10028	1	PSU 100-240V/0,35A - 12V/1,3A
11	72-01326	1	PRINT CONVEYOR TOASTER
12	83-07523	1	Cable router Ø10
13	78-03105	14	Nut
14	72-05524	1	FOIL FOR CT ADV
16	83-08688	2	bearing Ø8/12X12 M KRAVE TYPE B
17	83-09615	1	shaft UT550V/CT550 KOMPLET
18	82-06510	4	leg M8
19	83-07908	1	switch 2-POLET
20	83-09613	1	Drive shaft

### 3.2.10 Spare parts CT550 ADV P

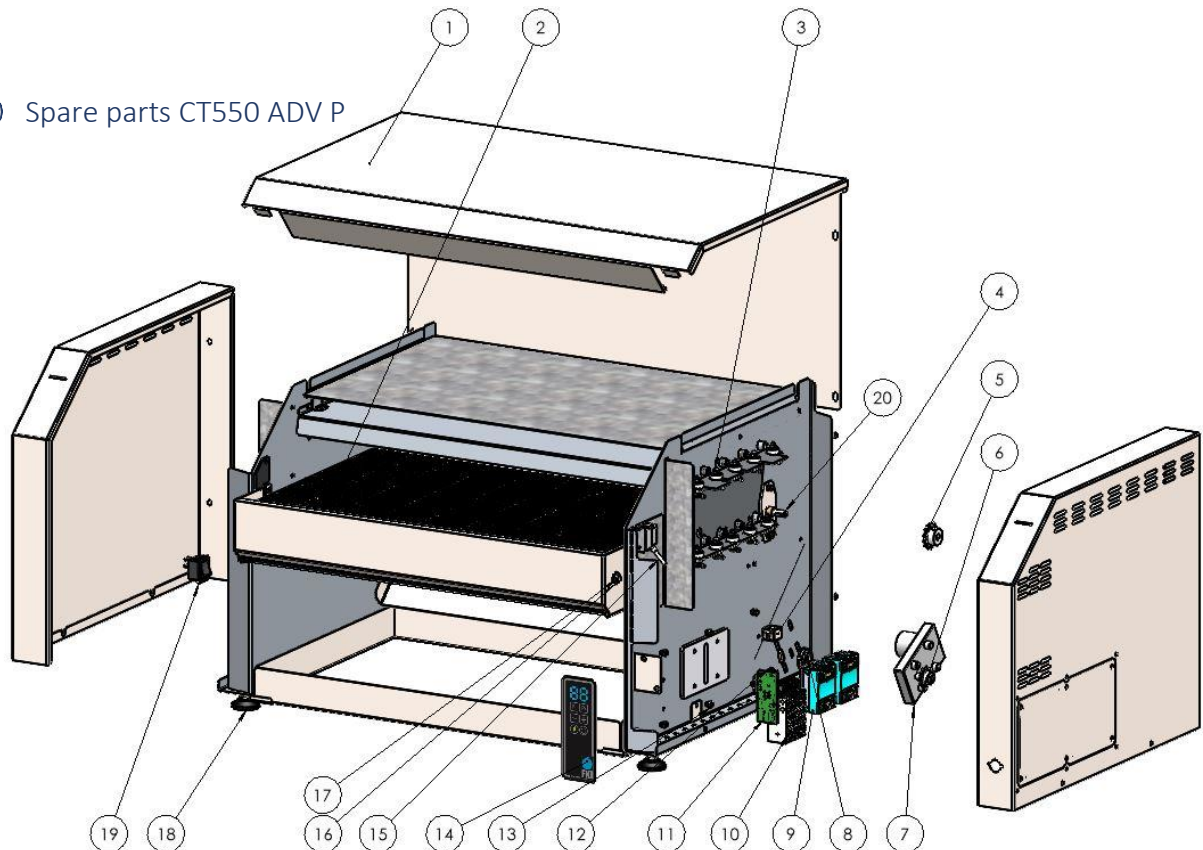

POS	VARE NUM-MER	STK	BENÆVNELSE
1	13-80555	1	Cabinet parts CT550 ADV
2	83-10343	1	Conveyor belt 559x1,83x12,7MM (920mm)
3	83-08596	20	insutator FOR QUARTTUBE
3	83-08595	10	QUARTSTUBE
3	83-08654	10	Heatelement
4	72-03508	1	Terminal 2-POL
5	83-08616	1	chainwheel 05B1 Z13 Ø8 M5 pinol
6	83-08584	1	chainwheel M8X3 Z10 Ø8 PINOL M4
7	83-10027	1	GEARMOTOR UT-V, DME34B5500B 24Vdc
8	72-07021	1	Cable connector M20 Ø3,5-8
9	88-00231	2	SOLIDSTATE 4-32VDC 48-660VAC 60A
10	83-10028	1	PSU 100-240V/0,35A - 12V/1,3A
11	72-01326	1	PRINT CONVEYOR TOASTER
12	83-07523	1	Cable router Ø10
13	78-03105	16	Nut
14	72-05524	1	FOIL FOR CT ADV
15	72-07033	1	SENSOR DIFFUS REFLEKTOR O6T304
16	83-08688	2	bearing Ø8/12X12 M KRAVE TYPE B
17	83-09615	1	shaft UT550V/CT550 KOMPLET
18	82-06510	4	leg M8
19	83-07908	1	switch 2-POLET
20	83-09613	1	Drive shaft

3.2.11 Electrical diagrams

1	2	3	4	5	6	7	8
<div style="display: flex; justify-content: space-around;"> <div style="text-align: center;"> <p>Heating element positioning</p> <p>CT 280/400 ADV/STD/MAN</p> </div> <div style="text-align: center;"> <p>Heating element positioning</p> <p>CT 280/400 ADV/STD P</p> </div> </div>							
<div style="display: flex; justify-content: space-around;"> <div style="text-align: center;"> <p>Heating element positioning</p> <p>CT 280/400 STD/MAN R</p> </div> <div style="text-align: center;"> <p>Heating element positioning</p> <p>CT 550 ADV/STD P</p> </div> </div>							
<p><b>FKI Fast Food Teknik a/s</b></p>		<p><b>Project title:</b> Conveyor Toaster - generic schematic</p> <p><b>Customer:</b> Overview</p> <p><b>Page title:</b> Electrical - Conveyor Toaster - Schematic</p> <p><b>File name:</b> Electrical - Conveyor Toaster - Schematic</p> <p><b>Page ref.:</b></p>		<p><b>Project no.:</b></p> <p><b>DCC:</b></p> <p><b>Dwg. no.:</b></p> <p><b>Eng. (proj/page):</b></p> <p><b>Appr. (date/mit):</b></p>		<p><b>Project rev.:</b></p> <p><b>Page rev.:</b></p> <p><b>Last print:</b></p> <p><b>Last edit:</b></p>	
				<p><b>Page</b></p> <p>Scale: 1:1</p> <p>Previous page:</p> <p>Next page: 1</p> <p>Total no. of pages: 10</p>		<p><b>Overview</b></p>	

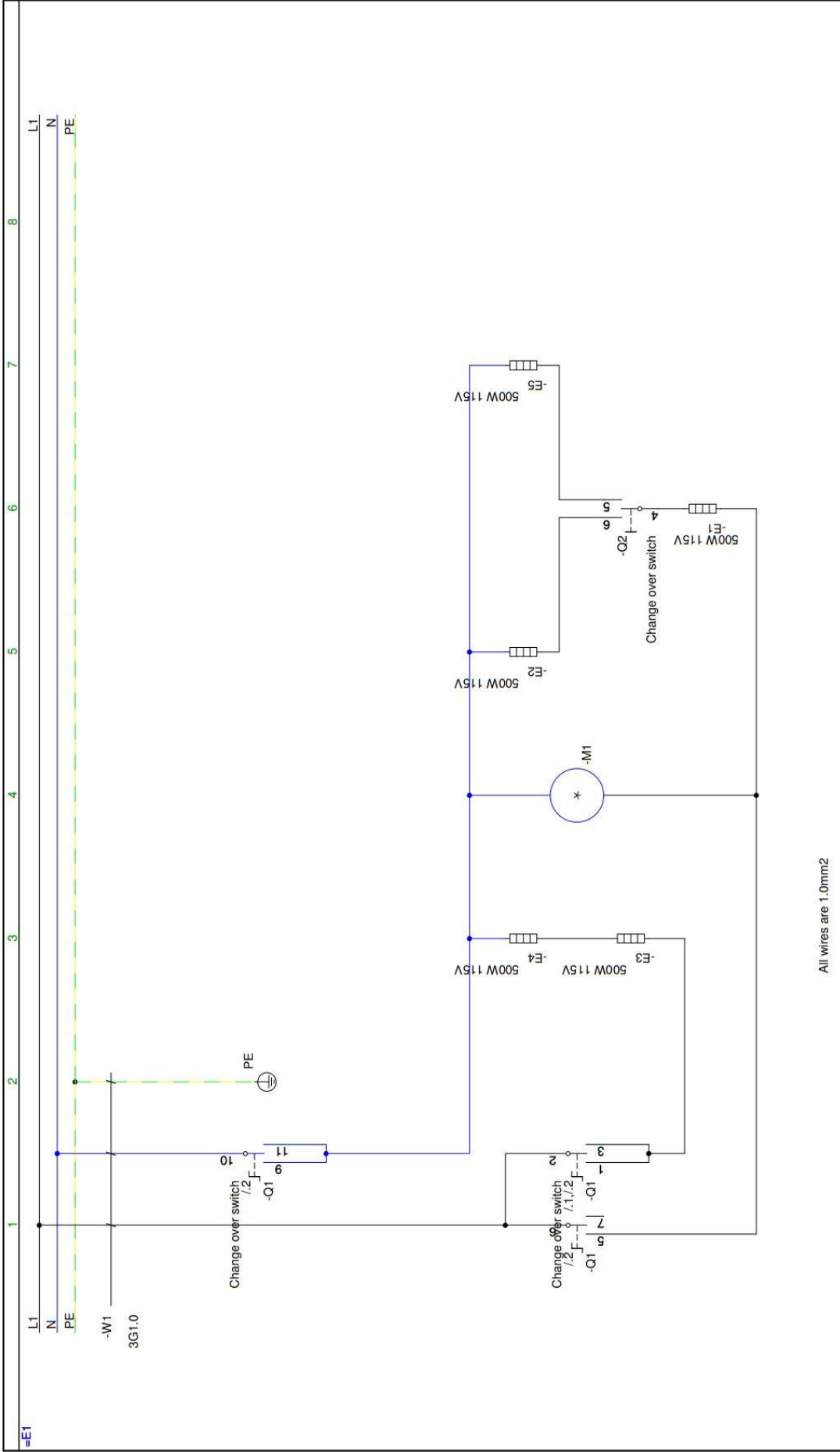

All wires are 1.0mm2

<b>Project title:</b> Conveyor Toaster - generic schematic	<b>Project no.:</b>	<b>Project rev.:</b>	<b>Page</b>
<b>Customer:</b> MAN	<b>DCC:</b>	<b>Scale:</b>	<b>1</b>
<b>Page title:</b> MAN	<b>Dwg. no.:</b>	<b>Page rev.:</b> Overview	<b>1:1</b>
<b>File name:</b> Electrical - Conveyor Toaster - Schematic	<b>Eng. (proj/page):</b>	<b>Last print:</b> 26/06/2024	<b>Next page:</b> 2
<b>Page ref.:</b> CT 280/400 MAN	<b>Appr. (date/init):</b>	<b>Last edit:</b> 01/02/2024	<b>Total no. of pages:</b> 10





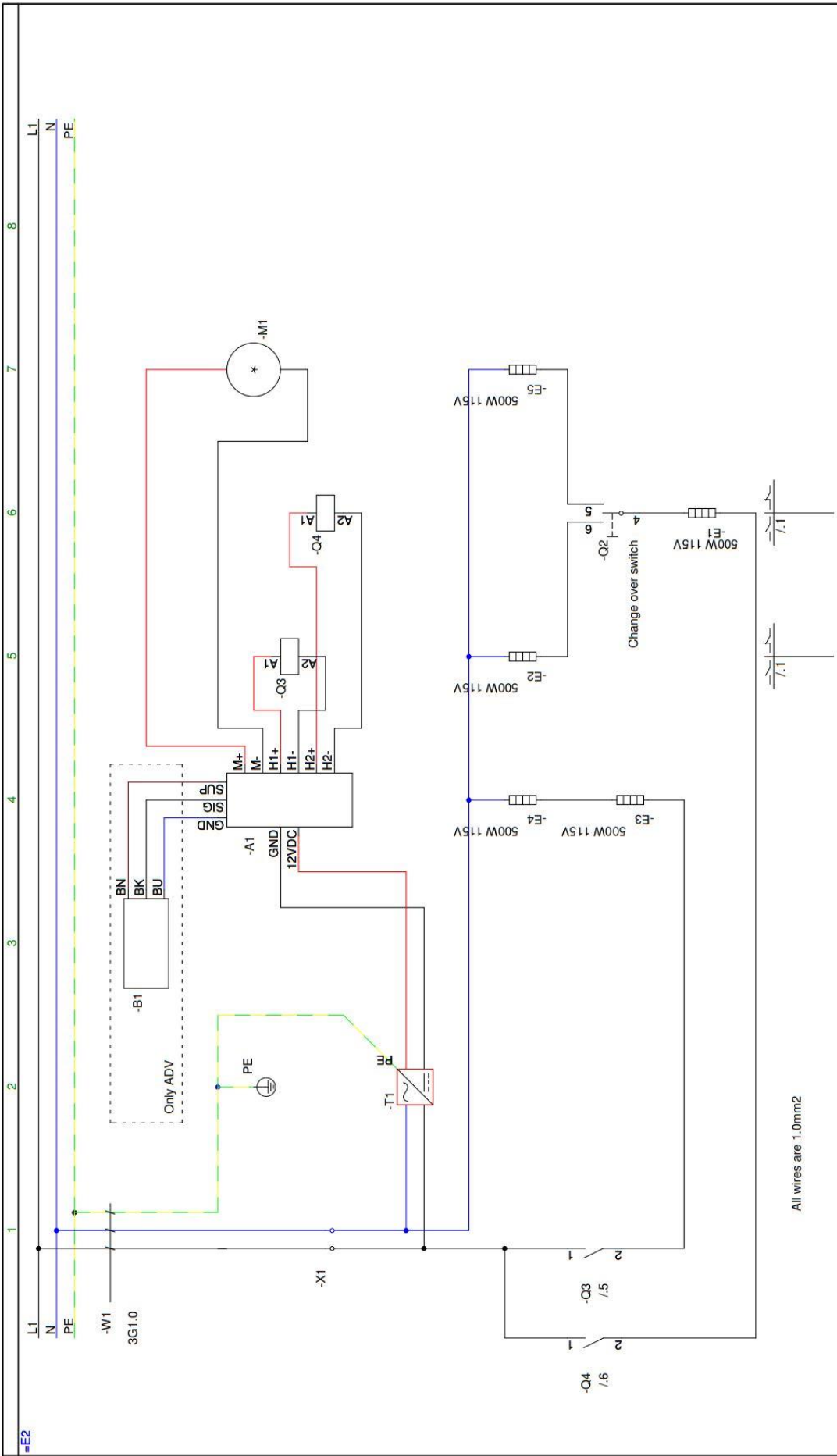

<b>Project title:</b> Conveyor Toaster - generic schematic	<b>Project no.:</b>	<b>Project rev.:</b>	<b>Page</b>
<b>Customer:</b> ADV / STD	<b>DCC:</b>	<b>Scale:</b>	<b>2</b>
<b>Page title:</b> Electrical - Conveyor Toaster - Schematic	<b>Dwg. no.:</b>	<b>Page rev.:</b>	<b>Scale:</b>
<b>File name:</b> CT 280/400 ADV/STD	<b>Eng. (proj/page):</b>	<b>Last print:</b>	<b>1:1</b>
<b>Page ref.:</b>	<b>Appr. (date/init):</b>	<b>Last edit:</b>	<b>1</b>
			<b>3</b>
			<b>10</b>



**FKI Fast Food Teknik a/s**

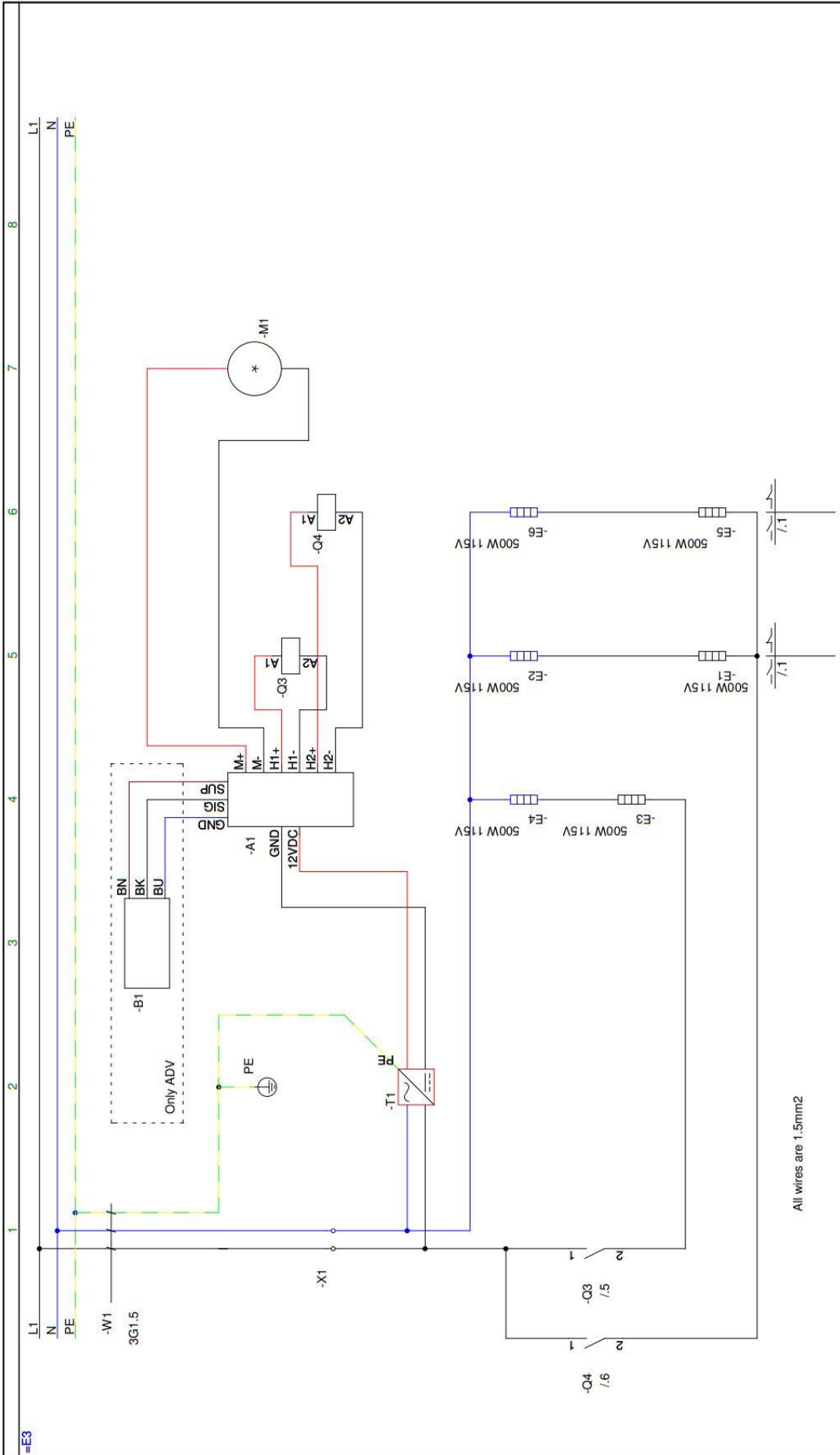

	<b>Project title:</b> Conveyor Toaster - generic schematic		<b>Project no.:</b>	<b>Project rev.:</b>	<b>Page</b>
	<b>Customer:</b> ADV / STD Performance	<b>DCC:</b>	<b>DCC:</b>	<b>Scale:</b>	<b>Scale:</b>
	<b>Page title:</b> ADV / STD Performance	<b>Dwg. no.:</b>	<b>Dwg. no.:</b>	<b>Page rev.:</b>	<b>Page rev.:</b>
	<b>File name:</b> Electrical - Conveyor Toaster - Schematic	<b>Eng. (proj/page):</b>	<b>Eng. (proj/page):</b>	<b>Last print:</b>	<b>Next page:</b>
	<b>Page rel.:</b> CT 280/400 ADV/STD P	<b>Page rel.:</b>	<b>Apr. (date/nt):</b>	<b>Last edit:</b>	<b>Total no. of pages:</b>
					10

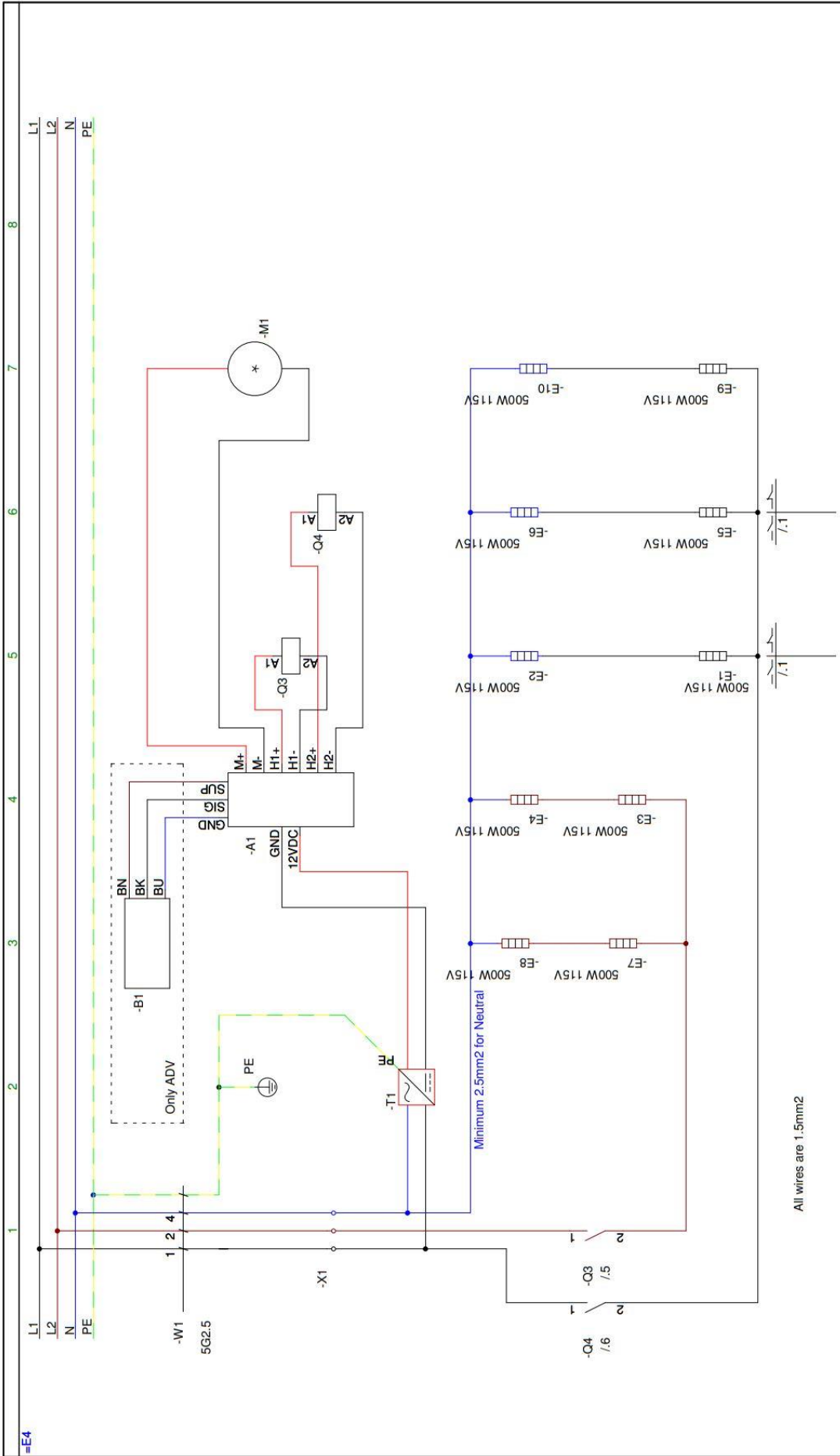

All wires are 1.5mm<sup>2</sup>

	<b>Project title:</b> Conveyor Toaster - generic schematic	<b>Project no.:</b>	<b>Project rev.:</b>	<b>Page</b>
	Customer: ADV / STD Performance	DCC:	Scale: 1:1	<b>4</b>
	File name: Electrical - Conveyor Toaster - Schematic	Eng. (proj/page):	Page rev.: Previous page: 3	<b>3</b>
	Page ref.: CT 550 ADV/STD P	Appr. (date/init):	Last print: 28/06/2024	<b>5</b>
			Last edit: 26/04/2024	<b>10</b>

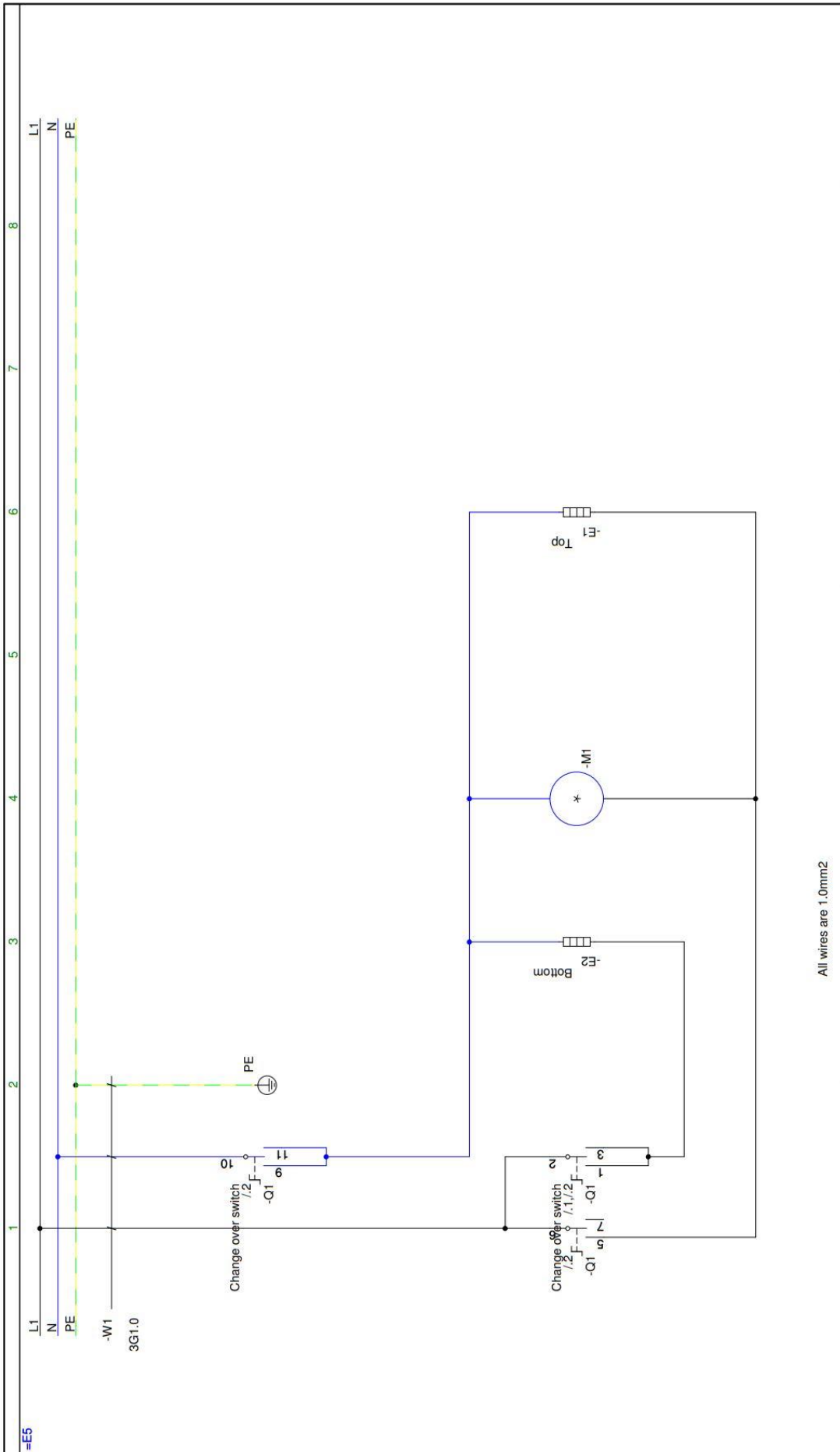

All wires are 1.0mm<sup>2</sup>

<b>FKI Fast Food Teknik a/s</b>		<b>Project title:</b> Conveyor Toaster - generic schematic	<b>Project no.:</b>	<b>Project rev.:</b>	<b>Page</b>
		<b>Customer:</b> MAN Rugged	<b>DCC:</b>		<b>Scale:</b> 1:1
		<b>Page title:</b> Electrical - Conveyor Toaster - Schematic	<b>Eng. (proj/page):</b>	<b>Page rev.:</b>	<b>Previous page:</b> 4
		<b>File name:</b> CT 280/400 MAN R	<b>Appr. (date/init):</b>	<b>Last print:</b> 26/06/2024	<b>Next page:</b> 6
				<b>Last edit:</b> 26/06/2024	<b>Total no. of pages:</b> 10

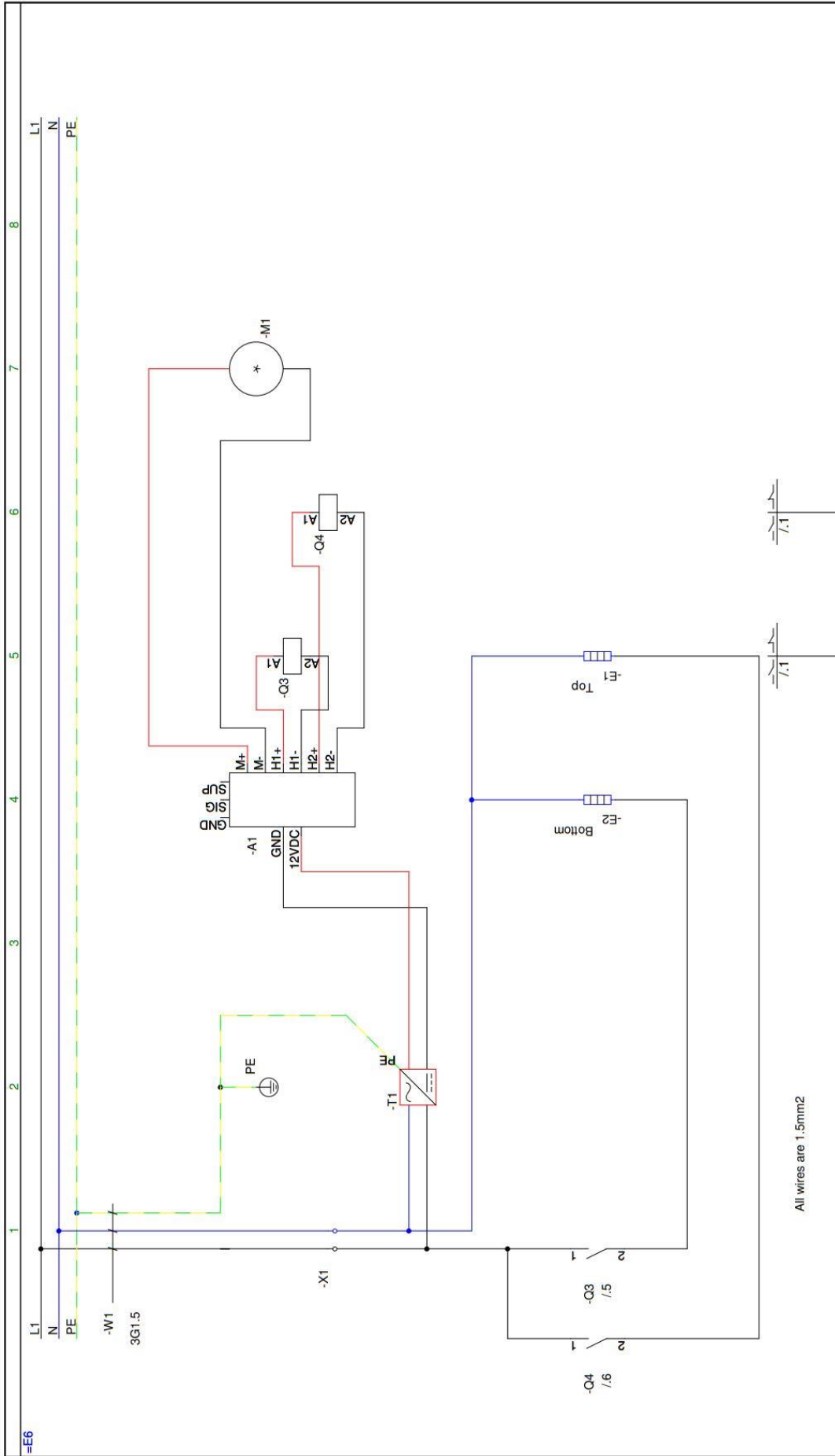

All wires are 1.5mm<sup>2</sup>

<b>Project title:</b> Conveyor Toaster - generic schematic	<b>Project no.:</b>	<b>Project rev.:</b>	<b>Page</b>
<b>Customer:</b> STD Rugged	<b>DOC:</b>	<b>Scale:</b> 1:1	<b>6</b>
<b>Page title:</b> Electrical - Conveyor Toaster - Schematic	<b>Dwg. no.:</b>	<b>Page rev.:</b>	<b>5</b>
<b>File name:</b> CT 280/400 STD R	<b>Eng. (prol/page):</b>	<b>Last print:</b> 26/06/2024	<b>7</b>
<b>Page ref.:</b>	<b>Appr. (date/init):</b>	<b>Last edit:</b> 25/06/2024	<b>10</b>



Component	Article no.	Type	Function	Description	Position
=E1-E1	83-08654	Heating Element	500W 115V		/1.6
=E1-E2	83-08654	Heating Element	500W 115V		/1.5
=E1-E3	83-08654	Heating Element	500W 115V		/1.3
=E1-E4	83-08654	Heating element	500W 115V		/1.3
=E1-E5	83-08654	Heating Element	500W 115V		/1.7
=E1-IM1	83-06515	Gear motor			/1.4
=E1-Q1	83-41018	M4H Z U3	Change over switch		/1.2
=E1-Q2	83-07954	SX82112811220000	Change over switch		/1.6
=E1-W1	72-03626	Cable	3G1.0		/1.1
=E2-A1	72-08012	Control			/2.4
=E2-B1	72-07033	Sensor	O6T304		/2.3
=E2-E1	83-08654	Heating Element	500W 115V		/2.6
=E2-E2	83-08654	Heating Element	500W 115V		/2.5
=E2-E3	83-08654	Heating Element	500W 115V		/2.4
=E2-E4	83-08654	Heating Element	500W 115V		/2.4
=E2-E5	83-08654	Heating Element	500W 115V		/2.7
=E2-IM1	83-10027	Gear Motor			/2.7
=E2-Q2	83-07954	SX82112811220000	Change over switch		/2.6
=E2-Q3	86-00231	Relay		SSR 4-32VDC	/2.5
=E2-Q4	86-00231	Relay		SSR 4-32VDC	/2.6
=E2-T1	83-10028	SMPS		RS15-12	/2.2
=E2-W1	72-03678	3G1,5	3G1.0	Cable 3G1,5	/2.1
=E2-X1	72-03508	Terminal Block			/2.1
=E3-A1	72-08012	Control			/3.4
=E3-B1	72-07033	Sensor	O6T304		/3.3
=E3-E1	83-08654	Heating Element	500W 115V		/3.5
=E3-E2	83-08654	Heating Element	500W 115V		/3.5
=E3-E3	83-08654	Heating Element	500W 115V		/3.4

Project title: Conveyor Toaster - generic schematic		Project no.:	Project rev.:	Page
Customer:		DCC:		Scale:
Page title:	Components list	Dwg. no.:		Previous page:
File name:	Electrical - Conveyor Toaster - Schematic	Eng. (proj/page):	26/06/2024	Next page:
Page ref.:		Appr. (date/init):	25/06/2024	Total no. of pages:
				10

Component	Article no.	Type	Function	Description	Position
=E3/-E4	83-08654	Heating Element	500W 115V		/3.4
=E3/-E5	83-08654	Heating Element	500W 115V		/3.6
=E3/-E6	83-08654	Heating Element	500W 115V		/3.6
=E3/-M1	83-10027	Gear Motor			/3.7
=E3/-Q3	88-00231	Relay		SSR 4-32VDC	/3.5
=E3/-Q4	88-00231	Relay		SSR 4-32VDC	/3.6
=E3/-T1	83-10028	SMPS		RS15-12	/3.2
=E3/-W1	72-03678	Main cable	3G1.5	Cable 3G1.5	/3.1
=E3/-X1	72-03508	Terminal Block			/3.1
=E4/-A1	72-08012	Control			/4.4
=E4/-B1	72-07033	Sensor	O6T304		/4.3
=E4/-E1	83-08654	Heating Element	500W 115V		/4.5
=E4/-E2	83-08654	Heating Element	500W 115V		/4.5
=E4/-E3	83-08654	Heating Element	500W 115V		/4.4
=E4/-E4	83-08654	Heating Element	500W 115V		/4.4
=E4/-E5	83-08654	Heating Element	500W 115V		/4.6
=E4/-E6	83-08654	Heating Element	500W 115V		/4.6
=E4/-E7	83-08654	Heating Element	500W 115V		/4.3
=E4/-E8	83-08654	Heating Element	500W 115V		/4.3
=E4/-E9	83-08654	Heating Element	500W 115V		/4.7
=E4/-E10	83-08654	Heating Element	500W 115V		/4.7
=E4/-M1	83-10027	Gear Motor			/4.7
=E4/-Q3	88-00231	Relay		SSR 4-32VDC	/4.5
=E4/-Q4	88-00231	Relay		SSR 4-32VDC	/4.6
=E4/-T1	83-10028	SMPS		RS15-12	/4.2
=E4/-W1	72-03674	Main Cable	5G2.5		/4.1
=E4/-X1	72-03509	Terminal Block			/4.1
=E5/-E1	83-08530 / 83-08531	Heating Element	Top		/5.6

Project title:	Conveyor Toaster - generic schematic	Project no.:	Project rev.:	Page
Customer:		DCC:		8
Page title:	Components list	Dwg. no.:	Page rev.:	1:1
File name:	Electrical - Conveyor Toaster - Schematic	Eng. (proj/page):	Last print:	7
Page ref.:		Appr. (date/init):	Last edit:	9
				Total no. of pages: 10



**FKI Fast Food Teknik a/s**





## 4 Cleaning

### 4.1 General



Remember to use personal safety equipment. see 2.1

Before using the appliance for the first time, wipe all surfaces that will be in contact with food with a damp cloth. Do not use cleaning products that contain acid.

### 4.2 Daily cleaning

Clean any excess cooking grease off the Appliance several times a day. If the Appliance has a grease drain, scrape any excess grease over to the drain hold so it can drain into a collection drawer. Empty the drawer and clean it as the need arises.

Thoroughly clean the heating surface of the Appliance once a day, wiping down all external surfaces with a damp cloth.

Never clean the Appliance when at temperatures above 50°C.

## 5 Disposal

### 5.1 Packaging

The packaging should not be left in the environment but should be disposed of in accordance with local regulations.

### 5.2 When the Appliance is no longer required

The Appliance is labelled with a recycling symbol in accordance with Danish Executive Order 148 of 8 February 2018 (Electronic Waste Executive Order/Elektronikaffaldsbekendtgørelsen). WEEE2 directive 2012/19/EU

This means that you must dispose of it in accordance with your municipality's regulations, e.g. in a container set up for this purpose at the municipality's recycling centre when the appliance is worn out.



## 6 EU DECLARATION OF CONFORMITY



EU DoC ID: FKI 018  
Verninge, 16-aug-2023

# EU DECLARATION OF CONFORMITY

We FKI Fast Food Teknik a/s declares under our sole responsibility that the product Conveyor Toaster with

Type Code.:

**ACT-23**

**SCT-23**

are in conformity with the following directive(s), standard(s) or other normative document(s), provided that the products are used in accordance with our instructions.

Directives	Standards
Machine Directive 2006/42/EC	EN/ISO 12100:2010
	EN/IEC 60335-1:2012
	EN/IEC 60335-1:2012/AC:2014
	EN/IEC 60335-1:2012/A11:2014
Electromagnetic Compatibility Directive 2014/30/EU	EN/IEC 60335-2-48:2003
	EN5501-1:2006 + A1:2009 + A2:2011
WEEE Directive 2012/19/EU	EN55014-2:1997 + A1:2001 + A2:2008
ROHS Directive 2011/65/EU	
Regulations	Standards
Food Contact Materials 1935/2004	N/A
Good Manufacturing Practice 2023/2006	

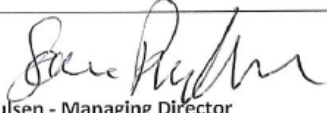
Date 16/8 - 2023	Issued by  Søren Poulsen - Managing Director
---------------------	--

FKI Fast Food Teknik a/s only vouches for the correctness of the English version of this declaration. In the event of the declaration being translated into any other language, the translator concerned shall be liable for the correctness of the translation.

Byghøjvej 5 · Verninge · DK-5690 Tommerup

## EU DECLARATION OF CONFORMITY

We FKI Fast Food Teknik a/s declares under our sole responsibility that the product Conveyor Toaster with

Type Code.:  
**MCT-23**

are in conformity with the following directive(s), standard(s) or other normative document(s), provided that the products are used in accordance with our instructions.

Directives	Standards
Machine Directive 2006/42/EC	EN/ISO 12100:2010 EN/IEC 60335-1:2012 EN/IEC 60355-1:2012/AC:2014 EN/IEC 60335-1:2012/A11:2014 EN/IEC 60335-2-48:2003
WEEE Directive 2012/19/EU ROHS Directive 2011/65/EU	

Regulations	Standards
Food Contact Materials 1935/2004 Good Manufacturing Practice 2023/2006	N/A

Date <b>16/8-2023</b>	Issued by  <b>Søren Poulsen - Managing Director</b>
--------------------------	--

FKI Fast Food Teknik a/s only vouches for the correctness of the English version of this declaration. In the event of the declaration being translated into any other language, the translator concerned shall be liable for the correctness of the translation.



# **Fast Food Teknik a/s**

Byghøjvej 5 · Verringe · DK-5690 Tommerup · Tel. +45 6475 1066 · [info@fki.dk](mailto:info@fki.dk) · [www.fki.dk](http://www.fki.dk)